

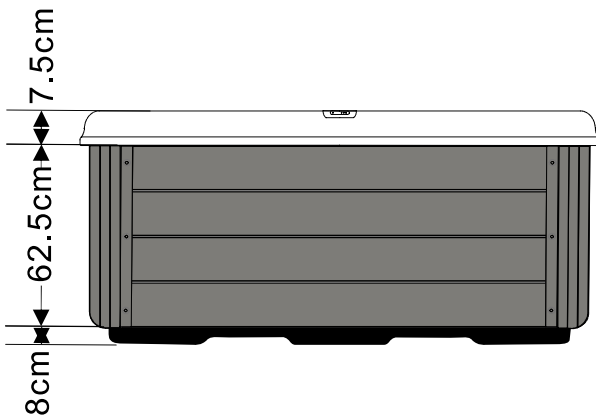

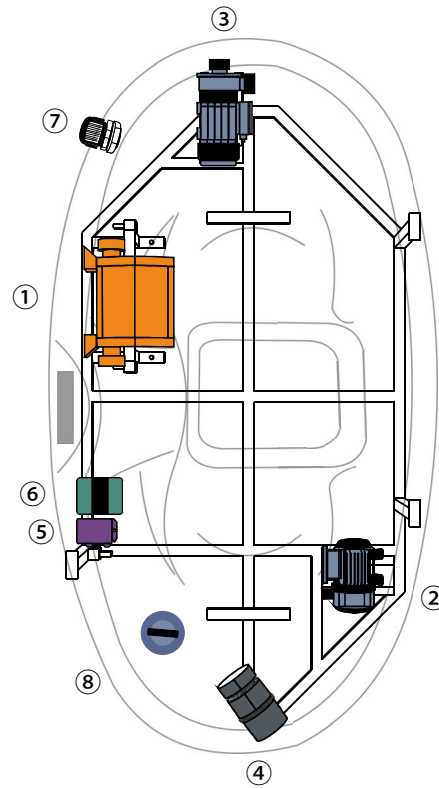

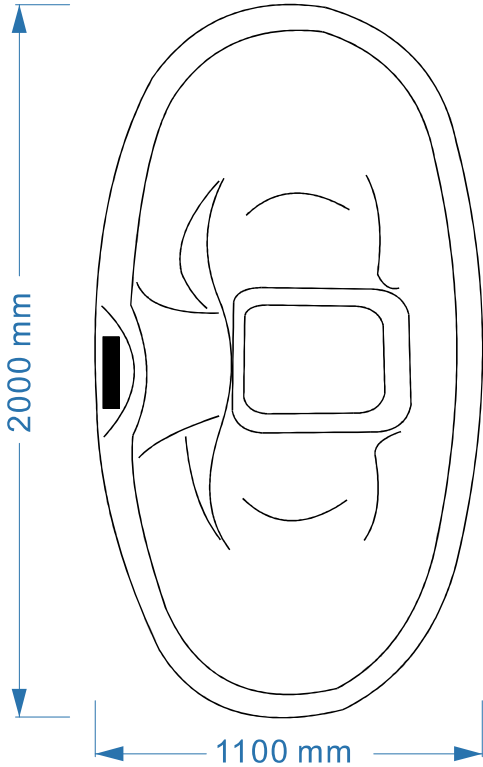



JCS-25:2000x1100x780mm

YE-3(V3)/Config 7/230v/1phase/13A



No. Items	Part n°
①	 Controller
②	 SPA circulation pump(WTC50)
③	 Massage pump 1:LP200
④	 Air pump(AP300)
⑤	 LED Synchronizer
⑥	 Ozone
⑦	 PG head
⑧	 Drainage